

IPG-8901597-8901601

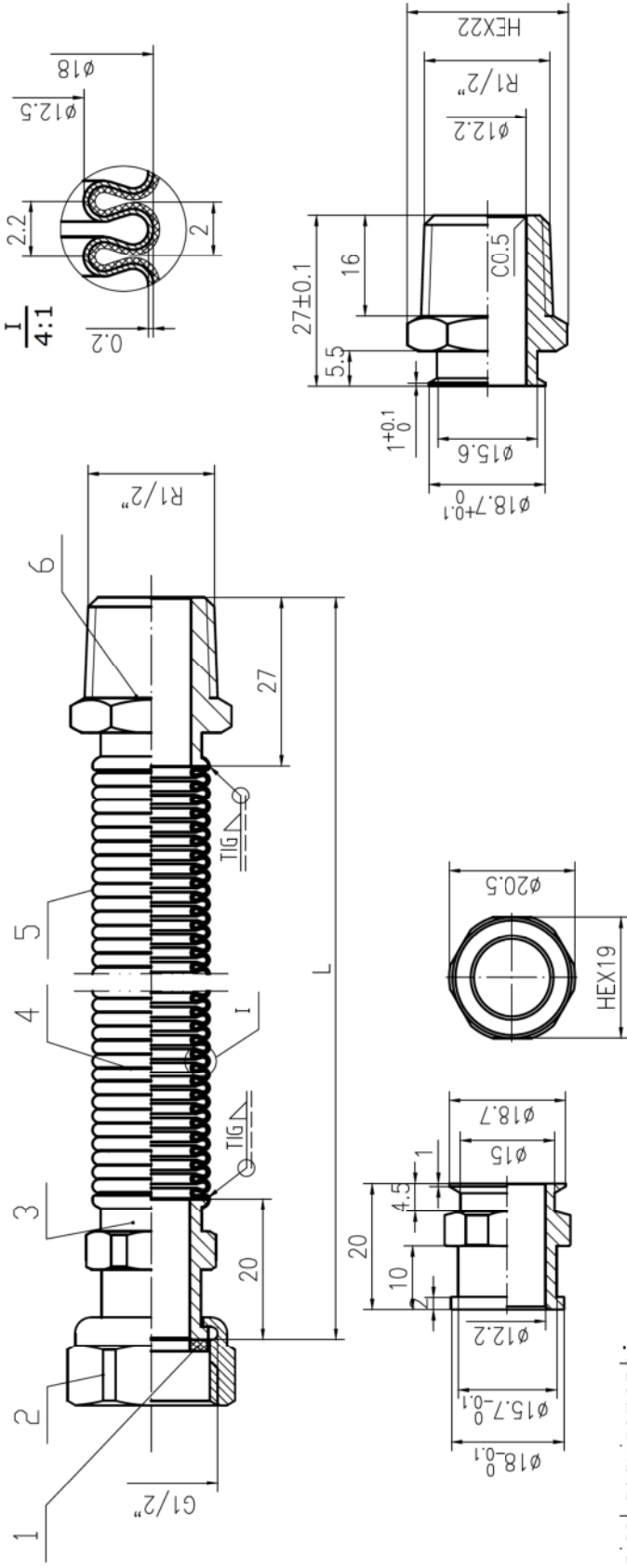

Technical requirement :

1. Annealing and compression after hose body with cover
2. weld joint to be uniform
3. No scratches or other defects on the surface of the hose
4. Wave uniformity
5. Working pressure 3Bar
6. Working temperature: Max 110°C

No.	Code	Name	QTY.	Material	Remarks
6	TZX-201-15-1	Male	1	ASTM304	
5	TZX-404-14-22	Heat shrink tube	1	PE	φ22
4	TZX-001-180-1	Metal hose	1	ASTM316L	φ18x0.2
3	TZX-308-15-1	Joint	1	ASTM304	
2	TZX-101-15-1	Nut	1	ASTM304	
1	TZX-401-15-1	Gaskets	2	NBR	φ18.7xφ12x2.7

designed	weight	scale
		1:1
checked	Sheet	approved

CODE	8901597	8901598	8901599	8901600	8901601
L	75/91	110/160	200/320	260/450	500/900

IPG	
1/2" MF PVC COVER	
IPG-8901597-8901601	